

# 200

200  
SERIES

INSTALLATION GUIDE



# 200

---

## SERIES

INSTALLATION GUIDE



# 200 SERIES

## INSTALLATION GUIDE

Before you begin your installation of a Sub-Zero 200 Series unit, there are a few things you should take special care to observe. By reading these introductory instructions carefully, you will make the installation procedure easier, problem-free and, most important, safe.

First, as you follow these installation instructions, take particular note of the **WARNING!** and **CAUTION!** symbols when they appear. This information is important for the safe and efficient installation of this Sub-Zero.

### **▲ WARNING**

alerts you to a hazard that may cause serious injury or death if precautions are not followed.

### **▲ CAUTION**

signals a hazard where minor injury or product damage may occur if you do not follow instructions.

Also, The printed instructions may signal an **IMPORTANT NOTE**, which highlights information that is especially important for a problem-free installation.

Second, make sure that the actual equipment that was shipped to you matches the design you are expecting to install. Sub-Zero 200 Series offers models 249R, 249RP, 249FF and 245.

Each of these design options has specific installation requirements, which means it is vital that the unit match your planning and space needs. Before you begin, check the exact model number you need against the model numbers on the shipping carton.

If the unit you receive does not match your requirements, contact your Sub-Zero dealer.

# 200 SERIES

## PRE-INSTALLATION SPECIFICATIONS

### PREPARING THE SPACE

**Step 1:** First, make sure that the opening where the Sub-Zero is to be installed is properly prepared. Refer to the Pre-Installation Specifications illustrations and chart to be sure the space dimensions, electrical service and plumbing are correct for the model you are about to install.

**IMPORTANT NOTE:** To operate properly, the door must open a minimum of 90°. Use a minimum 2" (51 mm) filler in corner installations to assure a 90° door opening. Allow enough clearance in front of the unit for full door swing.

**IMPORTANT NOTE:** Make sure the floor under the refrigerator is level with the surrounding finished floor. Protect a finished floor with plywood, cardboard or some other suitable material before moving the refrigerator across it.

### MODELS 249R, 249R, 249FF AND 245 ROUGH-IN REQUIREMENTS

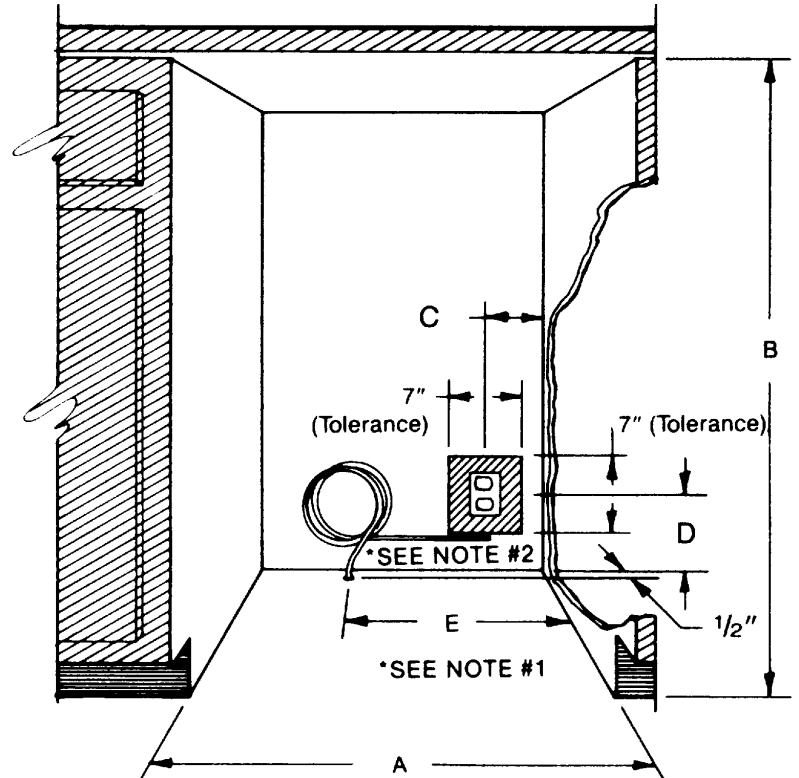

# 200 SERIES

## P R E - I N S T A L L A T I O N   S P E C I F I C A T I O N S

	Finished Rough Opening Width (A)	Finished Rough Opening Height (B)
<b>Model 249R</b>	24" (610)	34 1/2" (876)
<b>Model 249RP</b>	24" (610)	34 1/2" (876)
<b>Model 249FF</b>	24" (610)	34 1/2" (876)
<b>Model 245</b>	24" (610)	34 1/2" (876)

*NOTE: Dimensions in parentheses are in millimeters.*

*Refer to illustration on page 4.*

	Recommended Electrical Width Location (C)	Recommended Electrical Opening Height (D)
<b>Model 249R</b>	12" (305)	14" (356)
<b>Model 249RP</b>	12" (305)	14" (356)
<b>Model 249FF</b>	5" (127)	14" (356)
<b>Model 245</b>	5 1/2" (140)	4 1/2" (114)

*NOTE: Dimensions in parentheses are in millimeters.*

*Refer to illustration on page 4.*

	Door Panel Dimensions (Width x Height)
<b>Model 249R</b>	23 5/8" x 30" (600 x 762)
<b>Model 249RP</b>	23 5/8" x 30" (600 x 762)
<b>Model 249FF</b>	23 5/8" x 30" (600 x 762)
<b>Model 245</b>	23 1/2" x 28 1/8" (597 x 714)

*NOTE: Dimensions in parentheses are in millimeters.*

*Refer to illustration on page 4.*

# 200 SERIES INSTALLATION

## PREPARING ELECTRICAL CONNECTIONS

**Step 3:** To prepare the electrical system, rough in the electrical outlet following the Pre-Installation Specifications. You will need a 115 volt, 60 Hertz electrical supply. Dedicate a separate 15 amp fuse or circuit breaker to the Sub-Zero unit, and follow any local codes that apply.

The Sub-Zero unit comes with a power supply cord with a three-prong grounding plug. The refrigerator must be plugged into a mating three-prong wall receptacle grounded in accordance with the National Electrical Code and local codes.

### ⚠ WARNING

Do not use an extension cord, or two prong adapter. Electrical ground is required on this appliance.

Do not under any circumstances remove the power supply cord ground prong.

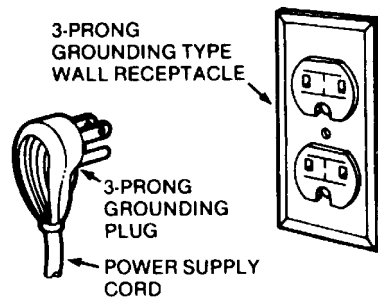

## PREPARING PLUMBING CONNECTIONS

**Step 4:** For units with automatic ice makers, first rough in the water supply line. Connect a 1/4" copper line to the house supply. Use an easily accessible shut-off valve between the supply and the refrigerator. This is usually about 6" (152 mm) from the compression fitting. The ice maker operates on water pressure of 20 psi (1.4 bar) to 100 psi (6.9 bar). But don't use a self-piercing valve. See your Sub-Zero dealer for a saddle valve kit, ask for part number 4200880.

*NOTE: Dimensions in parentheses are in millimeters.*

If the local water supply has high levels of sediment, consider adding an in-line filter.

Good water is important for good ice quality. It is not recommended that the ice maker be connected to a softened water supply. Water softener chemicals, such as salt from a malfunctioning softener, can damage the ice maker mold and lead to poor ice quality. If a softened water supply cannot be avoided, it is important that the water softener be well maintained and operating properly.

Reverse osmosis systems can be used, provided there is a consistent water pressure of 20 psi (1.4 bar) to 100 psi (6.9 bar) supplied to the water valve at all times.

Route the water line through the floor within 1/2" (13 mm) from the wall and no higher than 3" (76 mm) from the floor. If the water supply is brought in from behind the unit, route the water line through the wall no more than 3" (76 mm) from the floor. In either case, allow at least 3' (1 m) of excess copper tubing outside the wall or floor for easy connection to the refrigerator.

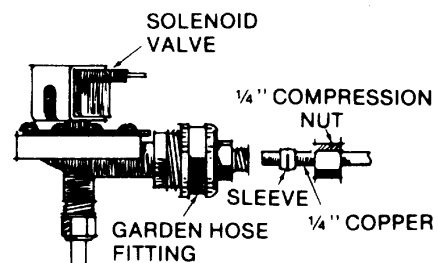
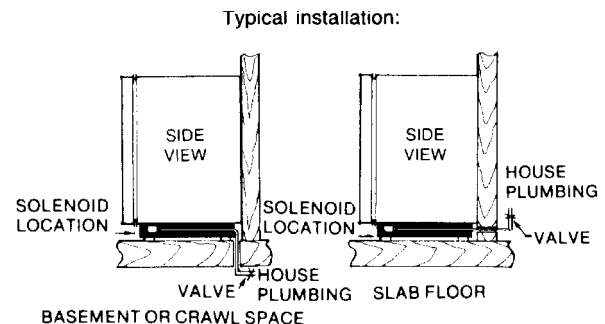

### ICEMAKER OPERATION:

After the water has been hooked up to the icemaker, lower stop arm of icemaker.

NOTE: You will need to allow some time for product to cool down sufficiently enough to produce ice. When the arm is down, it signals the icemaker that the ice supply is low and the icemaker automatically starts and replenishes the ice bucket. It will shut off automatically when the bucket is filled. The first time the icemaker operates, allow a few days for the bucket to fill. You might notice the first few crescents of ice are discolored. This is probably due to the new plumbing connection, and you should discard the first 3 dumps of ice. Ice, if kept over a period of time will stick together and crescents will shrink. To avoid this, empty the ice bucket at least once a month. (See Illustration 1.)

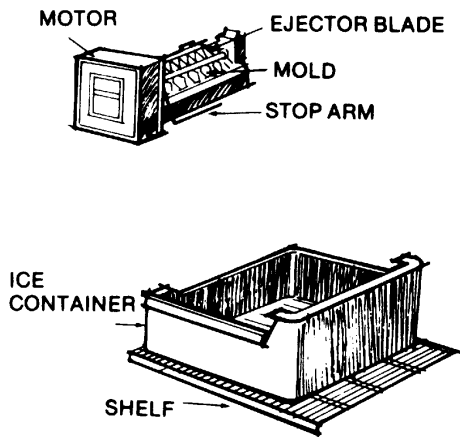

Illus. 1

### UNPACKING THE SUB-ZERO

**Step 5:** Unpack the unit, remove the unit shipping carton. Remove the wood base by extracting all 4 levelers and then discard the wood base. Reinstall all 4 levelers back into the unit base assembly. Remove all packing materials and tape as well. Do not discard the kickplate. Next, prelevel the unit by adjusting the leveler legs prior to pushing unit back into the installation.

**▲ WARNING**

Keep door(s) and drawer(s) taped closed while moving unit.

COMPLETING THE INSTALLATION

**⚠ CAUTION**

Protect any finished flooring before moving the unit in place. If for any reason the unit has been laid on its back or side, for over a hour, you must allow the unit to stand upright for a minimum of 24 hours before connecting power.

**Step 8:** To complete the installation, **first shut off power to the wall outlet.** Plug into a 15 amp grounded outlet and roll the unit into position. Now you have to connect the ice maker water line (if applicable). Remove the 1/4" compression fitting from its plastic bag and join the water supply line to the solenoid valve.

**IMPORTANT NOTE:** Make sure to purge the water line prior to hooking up the water valve.

**IMPORTANT NOTE:** Turn on the water supply and check all fittings for leaks. Make certain the electrical harness is attached to the solenoid.

In areas with water of high mineral content, the use of an in-line water filter is recommended. Make sure the filter is positioned and accessible for replacement when necessary.

**IMPORTANT NOTE:** Let your customer know that the ice maker will not fill with water immediately, and that the first three batches of ice produced should be discarded. Allow 24 hours to get proper ice production.

**Step 9:** Now, **level the unit.** Adjust both the front and rear levelers by turning the levelers clockwise - to raise the unit, counterclockwise - to lower the unit. When the unit is leveled properly, or squared off, door adjustments are less likely to be necessary. (See Figure 3.)

**IMPORTANT NOTE:** Be sure to reference leveling of the unit to the floor and not to surrounding cabinetry. This could effect the operation of the unit, such as door(s) not closing properly.

**Step 10:** After the unit has been leveled, install the kickplate as shown in illustration 2.

**⚠ CAUTION**

Do not block the kickplate louvers with carpeting, baseboard or other materials. This will cause poor operation or product failure.

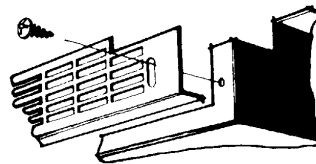

Illus. 2

(Figure 3)

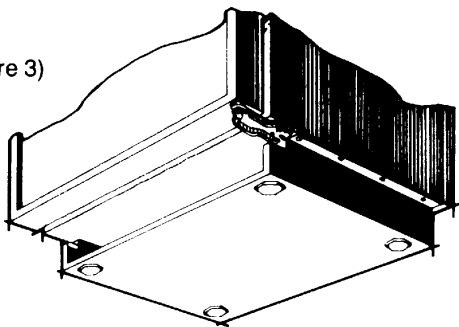



# 200 SERIES

## INSTALLING PANELS

Before you begin installing panels, refer to the Panel Specifications Dimensions on page 5, and be sure you are working with the Sub-Zero panel design called for in your installation plans. No panels or handle hardware are necessary to install.

## ACCOMMODATIONS FOR RAISED PANELS

You may have to rout, recess some door panel designs to allow for finger clearance. This is particularly true if your unit has raised panels greater than 1/4" (6) total thickness.

Check the location of offset when you're using specific routing for the grip area only. Refer to the 200 Series section of the Sub-Zero Design Guide for additional information.

All Sub-Zero undercounter units are manufactured in a manner to achieve a total built-in appearance. This allows you to choose the decorative material and color application for the front of your refrigerator/freezer. To install front panel on all Sub-Zero undercounter models:

1) Remove door handle. Handle is located on the top on the 245 model, and on the side on other models. Handle is held on with phillips head screws. (See illustrations 3 and 4.)

2) Slide 1/4" (6) thick panel into frame on door. Door must be opened 90° on 245 models. If a thinner panel is used, install chipboard filler panels behind the trim panel for proper fit.

**IMPORTANT:** Routing may be required on some raised panels for finger clearance under handle.

3) With panel in position, replace handle. Replace and tighten all screws. Do not overtighten and "strip" screws. Refer to pages 4 & 5 for installation dimensions. **NOTE:** 20# per door panel maximum weight limit.

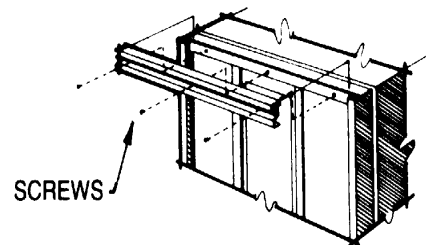

MODEL 245

Illus. 3

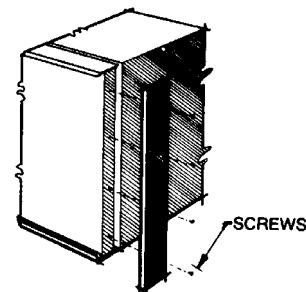

MODEL 249 SERIES

Illus. 4

*NOTE: Dimensions in parentheses are in millimeters.*

### ADJUSTING THE HINGES

It is possible that doors may come out of adjustment. If doors need adjustment, please refer to the following door adjustment directions.

**Model 249 Series:** Top and bottom hinges can be adjusted left to right and in & out, by loosening the two Phillips head screws. Model 245: Hinges are factory set; no field adjustment provided for. (See Illustration 5). Model 249 Series: Can be ordered either as a right-hand or left-hand product. Contact Sub-Zero dealer if swing change kit is required.

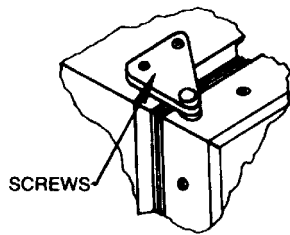

Illus. 5

### DOOR SWING CHANGE

**Model 245:** Upper; interchange hinge, screws and corner cap with hole plugs and corner cap on opposite side of cabinet and door. Lower; interchange hinge and screws with hole plugs on opposite side of cabinet. Move closer cam, screw and cam support plate to opposite side of door. (See Illustrations 6 & 7.)

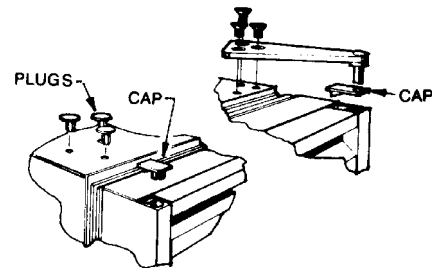

245 UPPER SWING CHANGE

Illus. 6

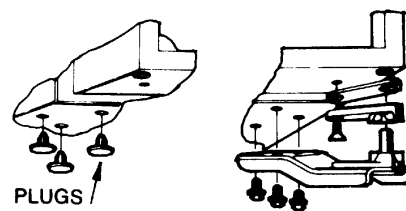

245 LOWER SWING CHANGE

Illus. 7

# 200 SERIES

## CHECKING THE RESULTS

That's it. You've completed the installation of a Sub-Zero 200 Series refrigerator/freezer. But you're not finished yet. Go over our checklist of installation steps.

- Has the packing material and tape been removed?
- Turn the unit on first, is the unit operating properly? If not, is it plugged in? Is the control turned on?
- Is the water supply line (if applicable) connected to the compression fitting and not leaking?
- Is the unit leveled properly on a solid floor?
- Has the door panel been installed properly?
- Is the kickplate installed?
- Are the kickplate screws back in position?
- Have the door hinge screws been tightened correctly?
- Are the doors adjusted for proper operation, sealing and alignment?
- Does your customer understand the unit's operation?
- Is the ice maker arm in on position (if applicable)?
- Have you given your customer the warranty package?

## SERVICE FOR YOUR SUB-ZERO REFRIGERATION SYSTEM

If you need service, check the model and serial number on the plate at the top frame of the unit inside the door.

Contact a Sub-Zero Factory Authorized Service Center, a dealer, or Sub-Zero Freezer Company, Customer Service Dept., P. O. Box 44988, Madison, WI 53744-4988, call 800-222-7820, or e-mail us at [customerservice@subzero.com](mailto:customerservice@subzero.com).

## THINK SAFETY!

If you are storing or disposing of your old refrigerator, please do it safely.

Child entrapment accidents can be tragic.

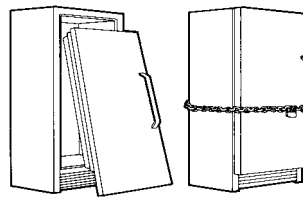

# 2000

200  
SERIES



SUB-ZERO FREEZER COMPANY, INC.

4717 Hammersley Road • Madison, Wisconsin 53711  
(800) 222-7820 • (608) 271-2233 • E-mail: [customerservice@subzero.com](mailto:customerservice@subzero.com)