



FAN COIL - BLOW THRU

BTW SERIES

FEATURES

- ' Seven models to choose from ranging in size from 6,000 to 36,000 BTUH
- ' Universal horizontal or vertical use
- ' Units are constructed of corrosion resistant aluminum and ABS plastic
- ' 1050 RPM motors for quiet operation
- ' Panels insulated internally to prevent external condensation
- ' Optional internally mounted incoloy rod type heating elements available for single phase input
- ' Three-way motorized water valve is standard with Pop-Top motor assembly
- ' Insulated and internally coated aluminum drain pan with anti-slosh foam media inside
- ' Condensate outlets (3/4") on both corners of the drain pan
- ' ABS blower housings with aluminum impellers
- ' Integral air bleeder for easy commissioning
- ' Units available for 115/1/60, 100/1/50, 208-230/1/60 and 200-220/1/50 power inputs.
- ' All unit coil assemblies are pressure tested to assure leak-proof performance
- ' All fan motors are test run to assure proper operation and air flow output

AQUA-AIR MANUFACTURING, division of the James D. Nall Co., Inc.
1050 East 9th Street, Hialeah, Florida 33010 U.S.A.
Ph. 305-884-8363 Fax 305-883-8549 Email sales@aquair.com

Technical Specifications								
Unit Size		06	09	12	18	24	30	36
Cooling Capacity	BTU/HR	6,000	9,000	12,000	18,000	24,000	30,000	36,000
	KCAL/HR	1,512	2,268	3,024	4,536	6,048	7,560	9,072
Air Flow Capacity	CFM	200	300	400	600	800	1,000	1,200
	M ³ H	340	510	680	1,020	1,360	1,700	2,040
Fan Amperage	115v	2.70	2.70	2.70	2.70	5.40	5.40	5.40
	230v	1.35	1.35	1.35	1.35	2.70	2.70	2.70
Fan Wattage	W	311	311	311	311	621	621	621
Required Chillwater Flow	GPM	1.2	1.8	2.4	3.6	4.8	6.0	7.2
	LPM	4.5	6.8	9.1	13.6	18.2	22.7	27.3
Pressure Drop	Ft/H ₂ O	2.7	6.5	4.8	6.2	7.6	9.4	11.1
	kPa	8.1	19.4	14.3	18.5	22.7	28.1	33.1
Maximum Heater Size	kW	1.0	1.5	2.0	3.0	4.0	5.0	6.0
	BTU/HR KCAL/HR	3,415 861	5,123 1,291	6,830 1,721	10,245 2,582	13,660 3,442	17,075 4,303	20,490 5,164
Auxiliary Heater Size	kW	1.0	1.0	1.0	1.5	2.0	3.0	3.0
	BTU/HR KCAL/HR	3,415 861	3,415 861	3,415 861	5,123 1,291	6,830 1,721	10,245 2,582	10,245 2,582
Weight	LBS	30.0	34.0	38.0	42.0	45.0	55.0	65.0
	KGS	13.6	15.5	17.3	19.1	20.5	25.0	29.5
Minimum Supply Air Grille Size	in ²	56	72	96	128	160	200	240
	cm ²	361	464	619	826	1,032	1,290	1,548
Minimum Return Air Grille Size	in ²	84	108	144	192	240	300	360
	cm ²	542	697	929	1,238	1,548	1,935	2,322

Unit Dimensions							
Unit Size	06	09	12	18	24	30	36
A	21" 534mm	25" 635mm	31" 788mm	39" 991mm	47" 1194mm	57" 1448mm	67" 1702mm
B	9-11/16" / 246mm						
C	18-13/16" / 478mm						
D	14-1/4" 362mm	18-1/4" 464mm	24-1/4" 616mm	32-1/4" 819mm	40-1/4" 1022mm	50-1/4" 1276mm	60-1/4" 1530mm
E	4" / 102mm						
F	10-13/16" / 275mm						
G	1/2" FPT Water Inlet						
G1	8-1/4" / 210mm						
G2	4-1/16" / 103mm						
H	1/2" FPT Water Outlet						
H1	7-3/4" / 197mm						
H2	11/16" / 18mm						
J	2-3/4" / 70mm						
K	1-7/8" / 48mm						
L	7/8" / 22mm Drain O.D.						

BTW-09 SHOWN
HORIZONTAL USE

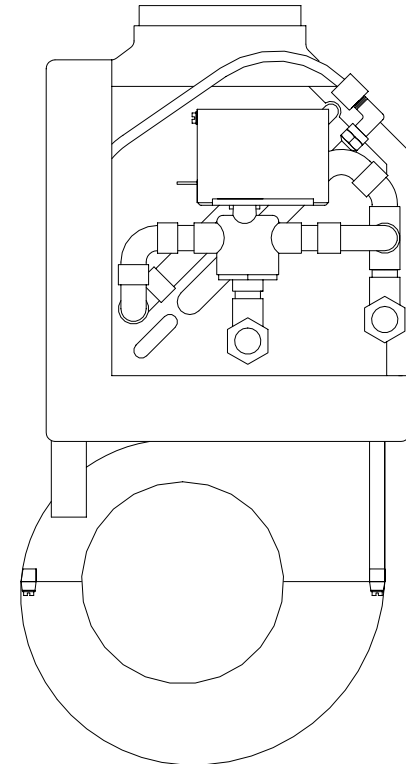
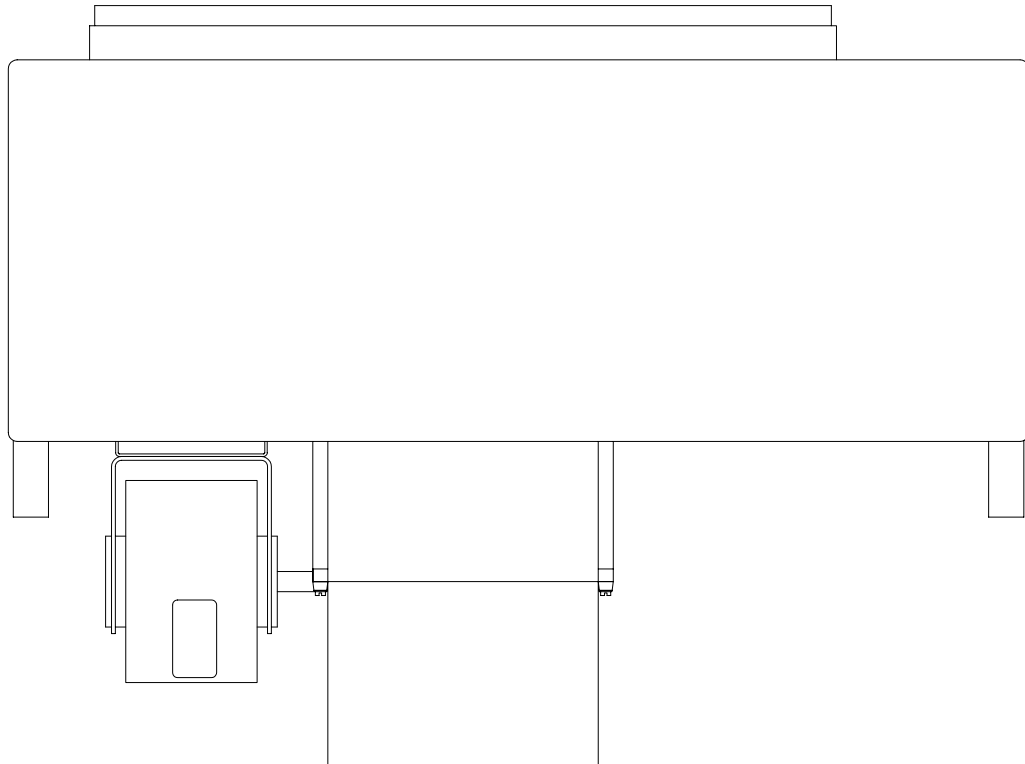
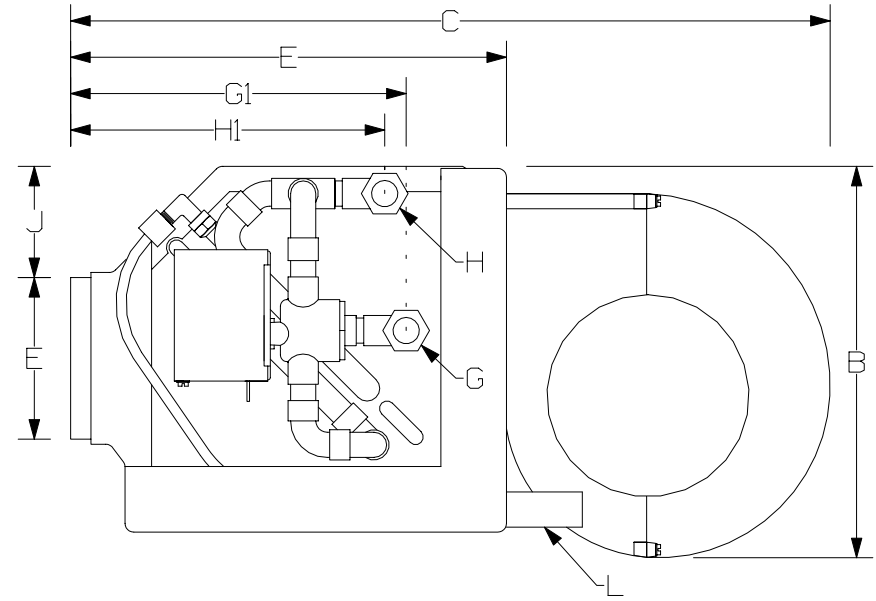
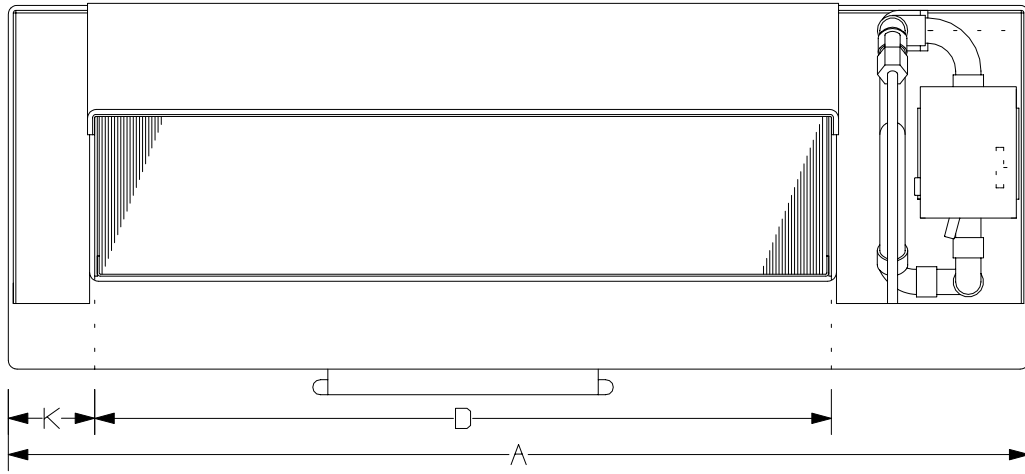

BTW-09
SHOWN
VERTICAL
USE

MULTIPLE FAN COILS CAN BE CONNECTED IN PARALLEL TO THE THERMOSTAT PROVIDED THEY DO NOT EXCEED THE MAXIMUM AMPERAGE RATINGS OF THE CONTROL MODULE

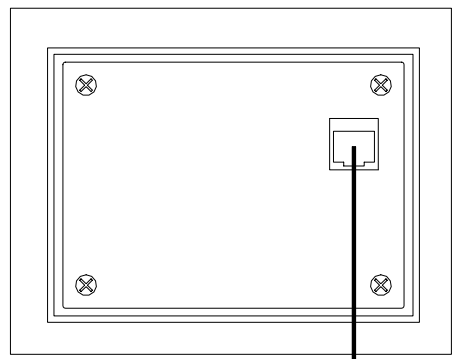

DISPLAY HEAD

INLET WATER SENSOR NOTE
ATTACH SENSOR TO THE WATER INLET LINE AT FAN COIL WATER VALVE

SENSORS

- INLET WATER SENSOR
- ROOM AIR SENSOR

DISPLAY CABLE 15'

CONTROL MODULE

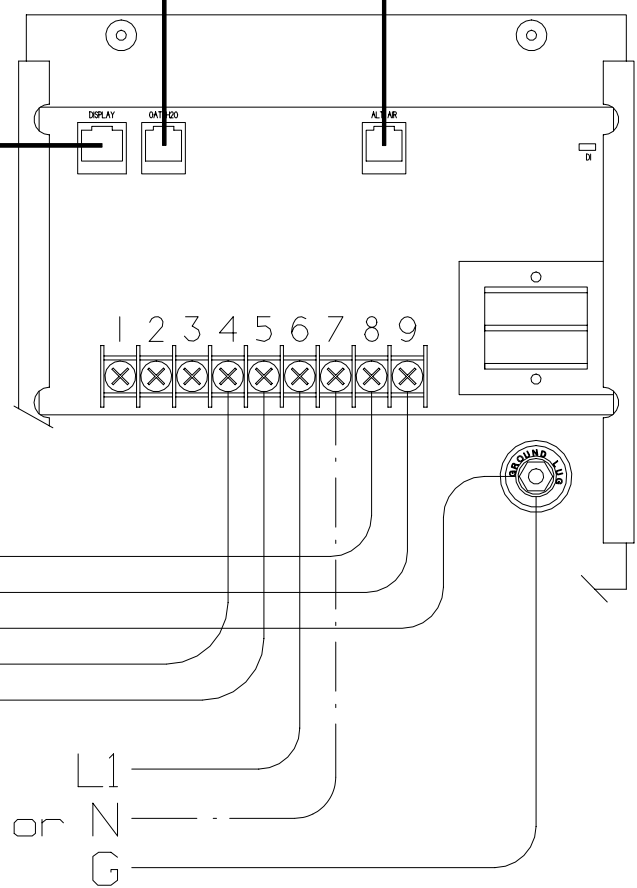

MAXIMUM CIRCUIT RATINGS
WATER VALVE 1/4A
FAN MOTOR 6A
HEATER 20A

TERMINAL BLOCK CONNECTIONS

1. HEATER ELEMENT L1
2. HEATER ELEMENT L2
3. N/A
4. WATER VALVE L2
5. WATER VALVE L1
6. POWER INPUT L1
7. POWER INPUT L2 or N
8. FAN L2
9. FAN L1

NOTE: ALL L2's ARE COMMON TO EACH OTHER

POWER INPUT
115/1/60
200-230/1/50-60

L1
L2 or N
G

NOTE: FAN COIL MOTOR & WATER VALVE MUST BE RATED FOR THE SAME VOLTAGE AS THE POWER INPUT.

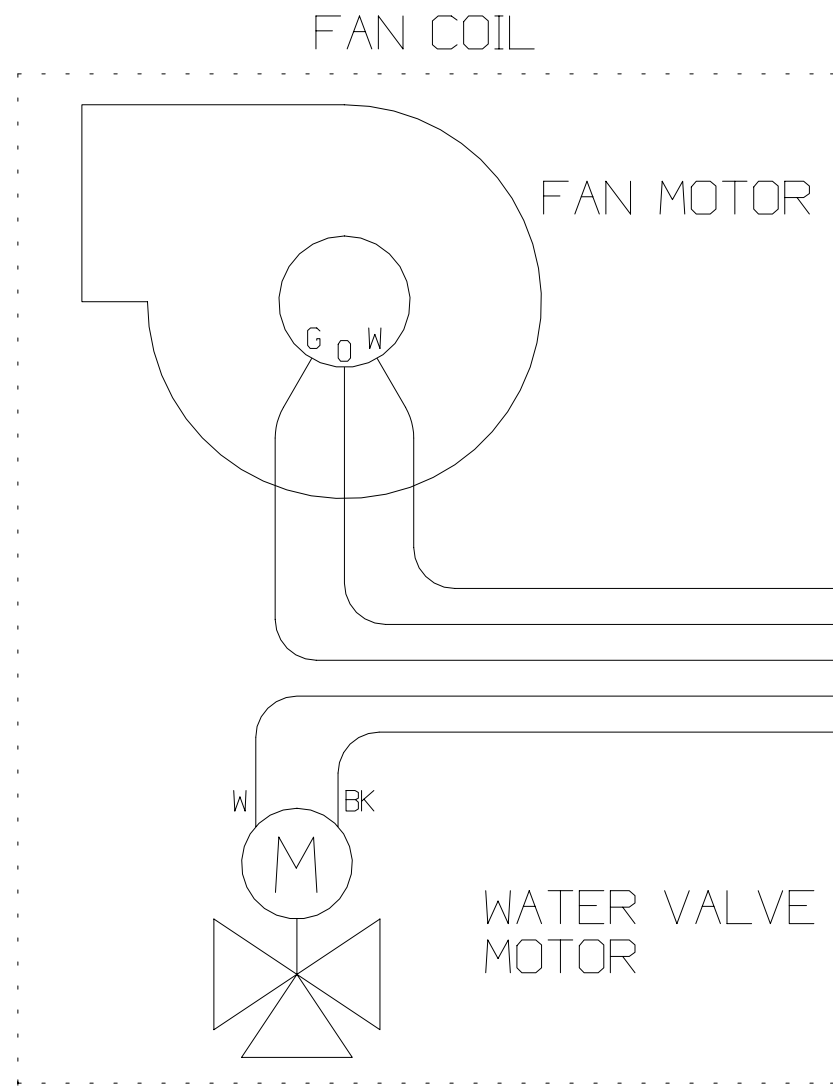

AQUA-AIR MARINE AIR CONDITIONING SYSTEMS			
TW2W DIGITAL THERMOSTAT w/ SINGLE BTW Series STYLE FAN COIL 115 or 230V COOLING ONLY or with HOT WATER HEAT			
DRAWING NUMBER	4008-34B	DRAWN BY	DN
		DATE	991026
SCALE	NONE	APPROVED BY	REVISION DATE
			REV A