



FRESH AIR MAKEUP UNIT AQFAH SERIES

FEATURES

- Four models to choose from ranging in size from 200 to 900 CFM
- Units are constructed of corrosion resistant aluminum
- Hi-static fan motors for extensive fresh air ducting networks
- Removable access panels on both the top and sides are insulated internally to prevent external condensation
- Washable air inlet filter
- Internally mounted INCOLOY rod type heating elements for cold weather operation down to 23 deg Fahrenheit (-5 deg Centigrade)
- Modulating chillwater flow valve for precise air temperature control in the cooling mode
- Modulating SCR heater element control for precise air temperature control in the heating mode
- Insulated and internally coated aluminum drain pan with ant-slosh foam media inside
- Condensate outlets on both sides of the fan coil
- All unit coil assemblies are pressure tested to assure leak-proof performance
- All units are test run to assure proper operation and air flow output

AQFAH UNIT SPECIFICATIONS

SPECIFICATION		02	04	06	09
NOMINAL CAPACITY	CFM	200	400	600	900
	CMH	340	680	1020	1530
WEIGHT	LBS	45.0	55.0	59.0	63.0
	KGS	20.5	25.0	26.8	28.6
LENGTH	IN	34			
	MM	864			
WIDTH	IN	23-3/4			
	MM	603			
HEIGHT	IN	11-3/4	21-3/16		
	MM	299	538		
POWER SUPPLY		208-230 / 1 / 60		200-220 / 1 / 50	
AMP DRAW @ 230-1-60		10.4	19	28	42
POWER	W	2460	4437	6644	10056
STANDARD HEATER SIZE	KW	2	4	6	9
CHILLWATER INLET / OUTLET	FPT	1/2"	3/4"	1"	1"
CHILLWATER FLOW	GPM	5.3	10.5	15.8	23.7
	LPM	19.9	39.8	59.8	89.7
DUCT CONNECTION	IN	5-7/8 x 10-1/4	10-7/16 x 11-15/16		
	MM	149 x 260	265 x 303		
MINIMUM INTAKE GRILLE	IN ²	60	120	180	270
	CM ²	390	775	1160	1740
DRAIN FITTING	FPT	3/4" 2 / UNIT			
MAIN BREAKER SIZE		15A	25A	35A	50A

80948.WPD

AQUA-AIR MANUFACTURING, division of the James D. Nall Co., Inc.
1050 East 9th Street, Hialeah, Florida 33010 U.S.A.
Ph. 305-884-8363 Fax 305-883-8549 Email sales@aquair.com

AQFAH-04 to 09
FRESH AIR
MAKE-UP UNIT
4-900 CFM NOM.

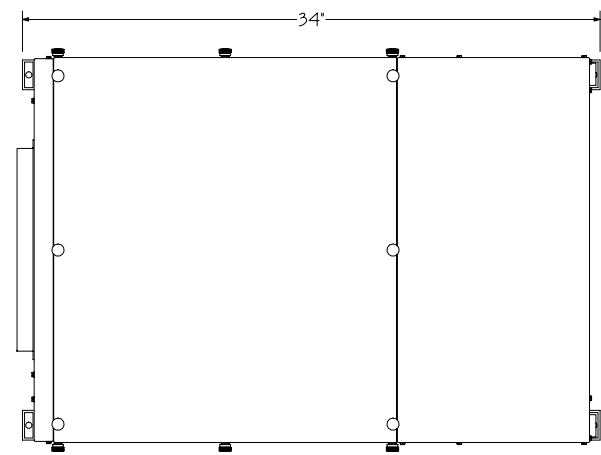

TOP VIEW

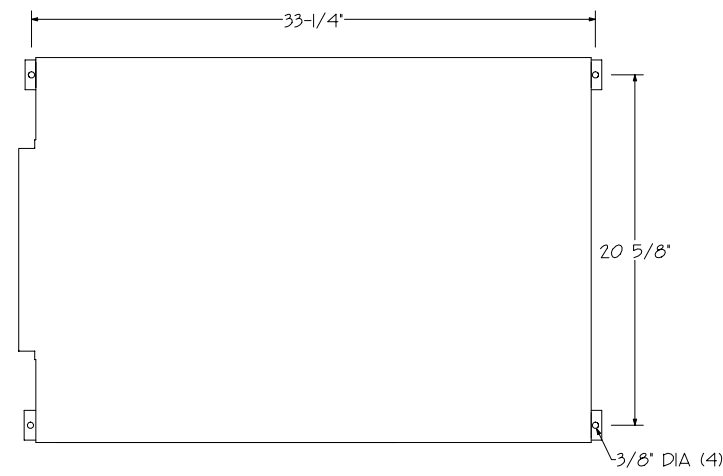

FOOTPRINT

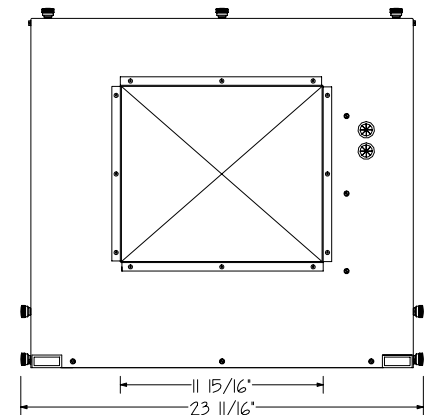

REAR VIEW

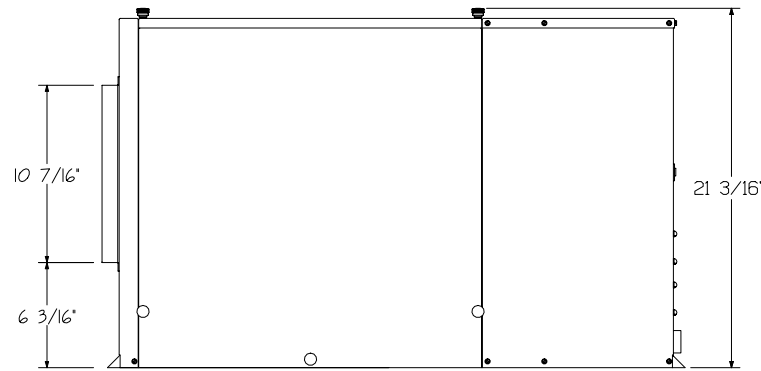

SIDE VIEW

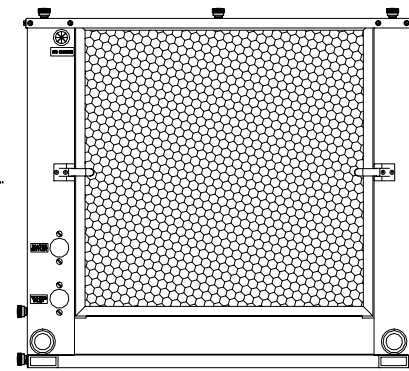

FRONT VIEW

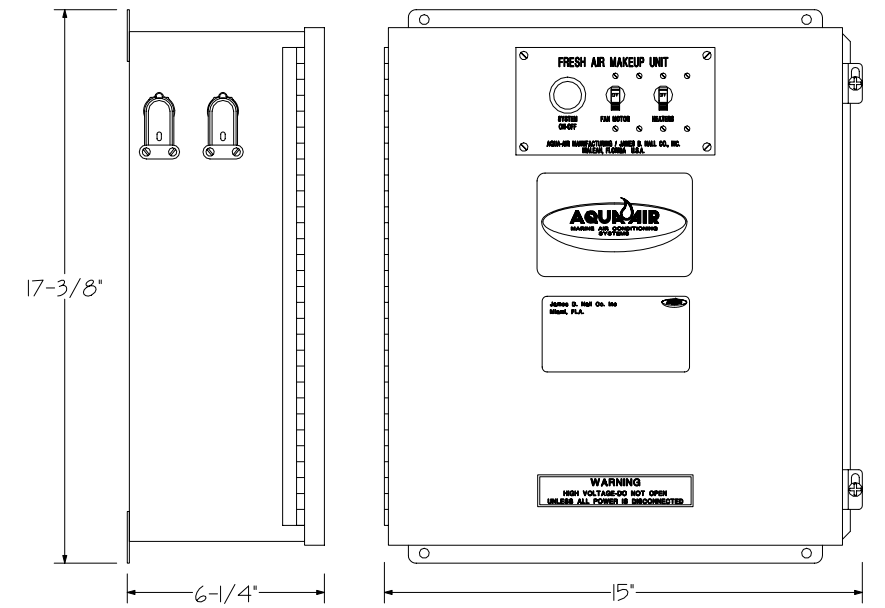

ELECTRICAL BOX FOR
AQFAH SERIES UNITS

NOT TO SCALE

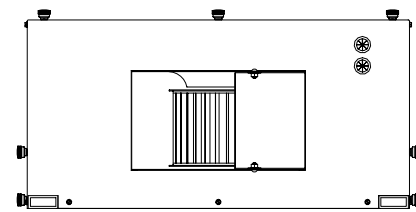

REAR VIEW

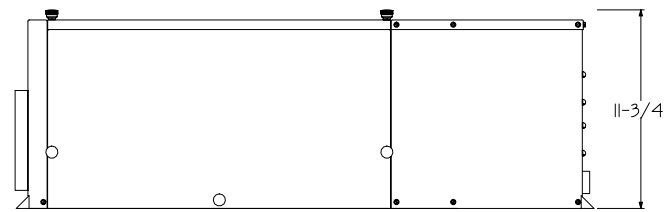

SIDE VIEW

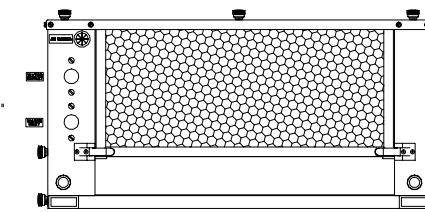

FRONT VIEW

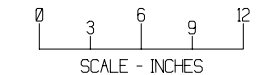

SCALE - INCHES



SCALE - MILLIMETERS

AQFAH-02
FRESH AIR
MAKE-UP UNIT
200 CFM NOM.

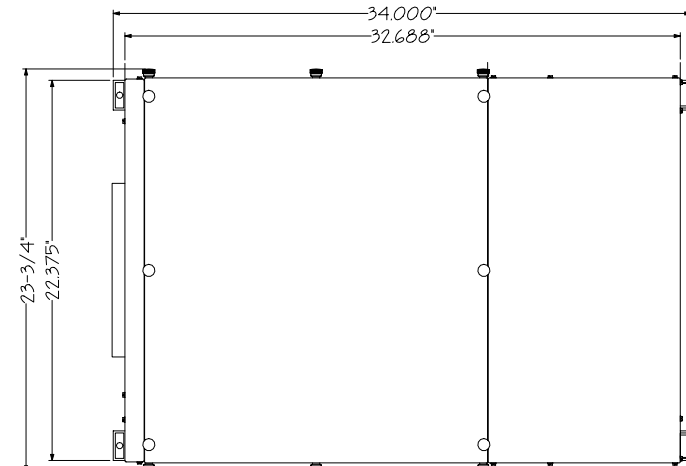

TOP VIEW

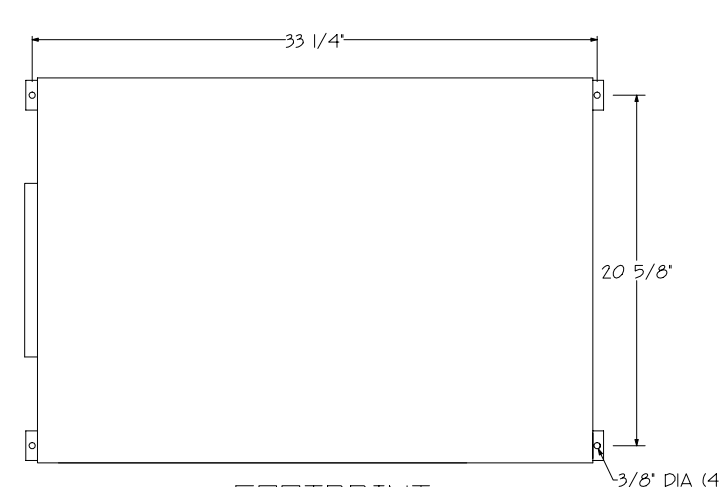

FOOTPRINT

AQUAIR MARINE AIR CONDITIONING SYSTEMS			
AQFAH-02 to 09 FRESH AIR MAKEUP UNITS			
DRAWING NUMBER	DRAWN BY	DATE	REV
AQFAH	DN	2-95	A
SCALE	APPROVED BY	REVISION DATE	