

Features

- ▶ High Efficiency Scroll Compressors
- ▶ Stainless steel, copper brazed plate heat exchangers
- ▶ Multi-circuit cupronickel heat exchanger
- ▶ Compact design
- ▶ Stainless steel drain pan/base
- ▶ Low and high refrigerant pressure access ports
- ▶ Low and high refrigerant pressure safety switches
- ▶ Unit mounted electrical component enclosure
- ▶ All units are precharged and fully run tested with **R-407C Refrigerant**
- ▶ Solid state digital temperature controller
- ▶ Available in 208/230-3-60, 460-3-60, 220-3-50 and 380/415-3-50
- ▶ Available in Cooling Only or Reverse Cycle configuration

Specifications		AC07 GD	AC07 GDK	AC07 GE	AC07 GEK	AC10 GD	AC10 GDK	AC10 GE	AC10 GEK
Capacity	BTU/H	90,000				120,000			
	Kcal/H	22,500				30,000			
	Tons	7.5				10			
Length	inches	27.00							
	mm	686							
Width	inches	17.50							
	mm	445							
Height	inches	28.5				31			
	mm	724				787			
Weight	lbs	250				270			
	kg	113				122			
Power Supply		208-3-60	220-3-50	460-3-60	380-3-50	208-3-60	220-3-50	460-3-60	380-3-50
Amp Draw		21.0	22	10	11	27.0	30.4	13.4	15.2
Power	Watts	5,370	5,240	5,750	5,240	7,770	8,050	7,770	8,050
Minimum Chillwater Flow Rate	GPM	18				24			
	LPM	68				91			
Chillwater Inlet/Outlet		1-3/8" OD Male hose connection				1-5/8" OD Male hose connection			
Minimum Seawater Flow Rate	GPM	30				40			
	LPM	114				152			
Seawater Inlet/Outlet		1-5/8" OD Male hose connection				1-5/8" OD Male hose connection			

i:\wordpfc\80967-1A.wpd

AQUA-AIR MANUFACTURING, division of the James D. Nall Co., Inc.
1050 East 9th Street, Hialeah, Florida 33010 U.S.A.
Ph. 800-328-1043 305-884-8363 Fax 305-883-8549
sales@aquair.com www.aquair.com

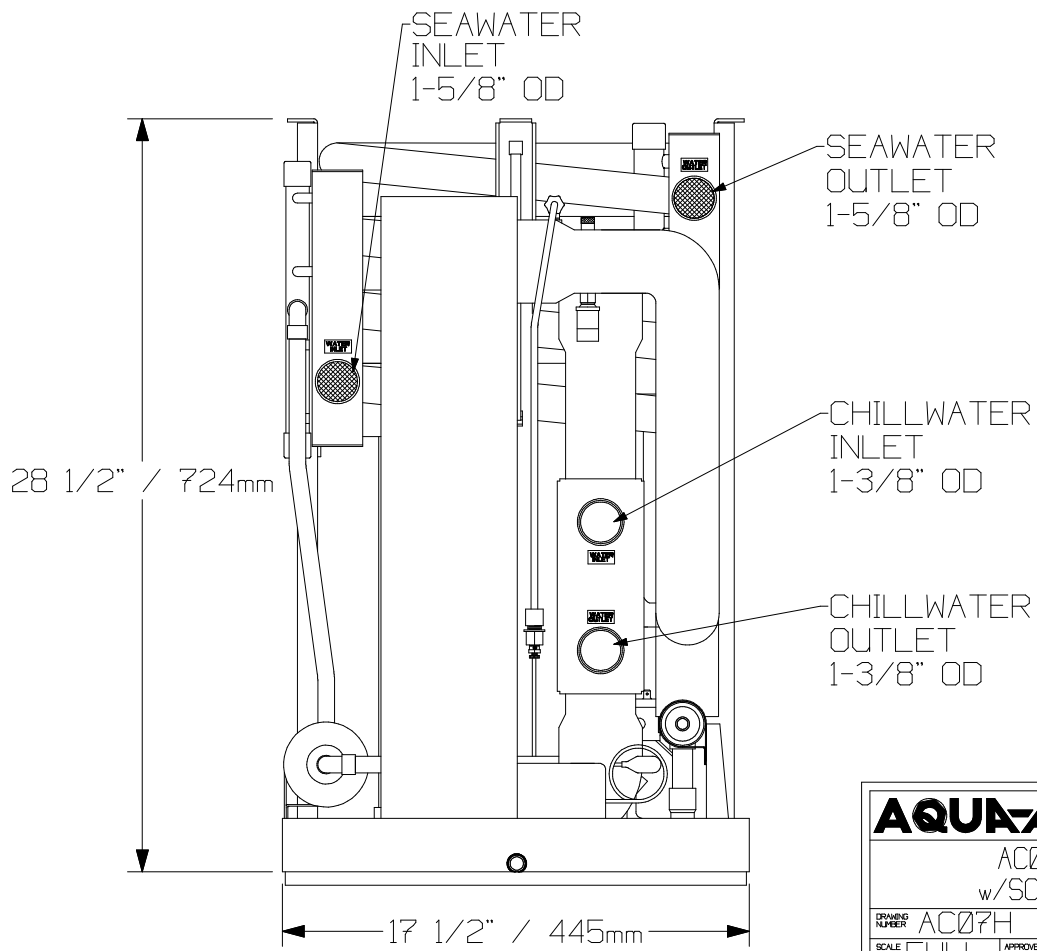
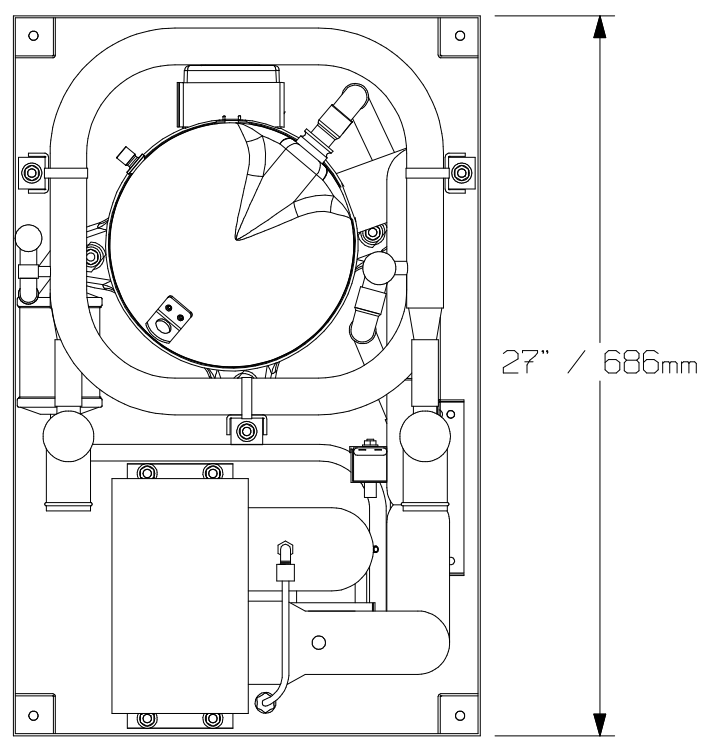
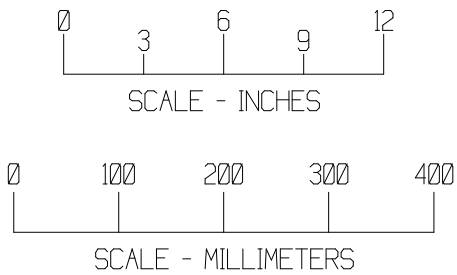

AQUA-AIR		MARINE AIR CONDITIONING SYSTEMS	
AC07H CHILLER UNIT w/SCROLL COMPRESSOR			
DRAWING NUMBER	AC07H	DRAWN BY	SB
SCALE	FULL	DATE	06-15-09
APPROVED BY	DN	REVISION DATE	REV

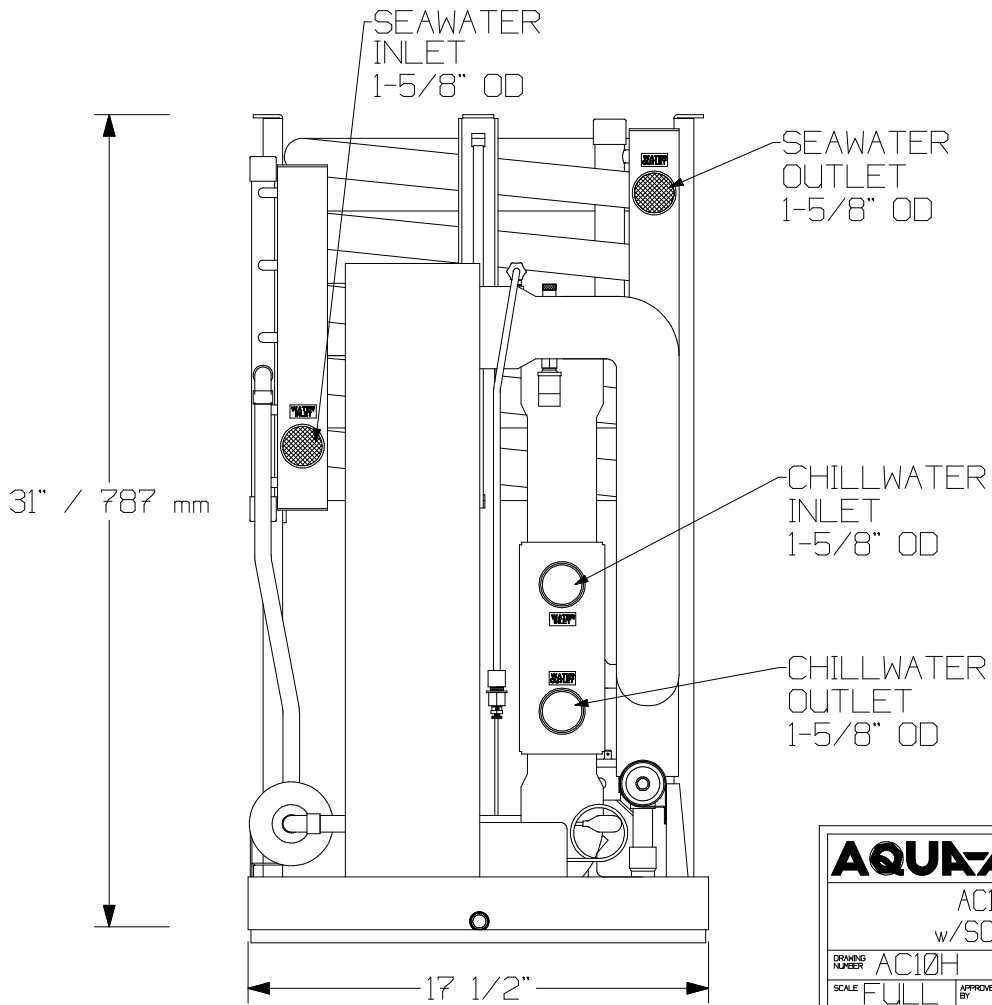
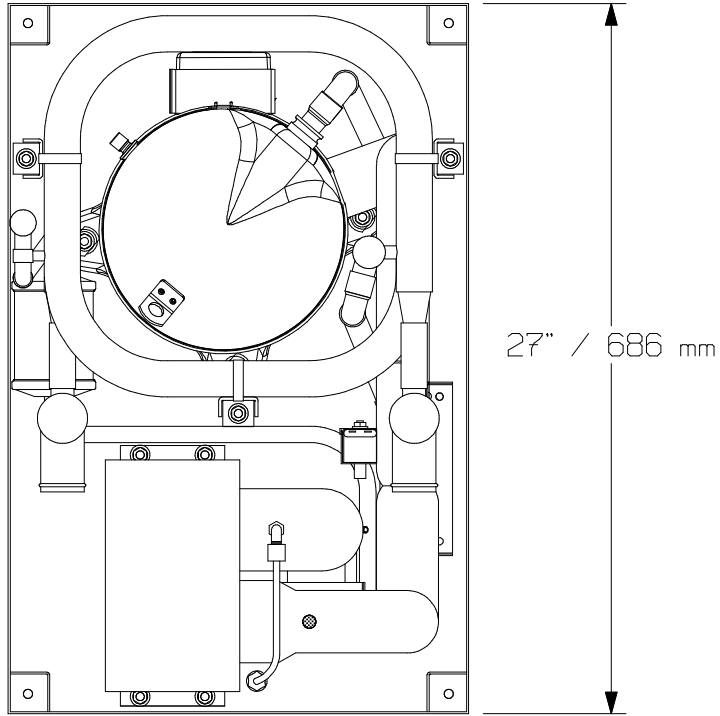
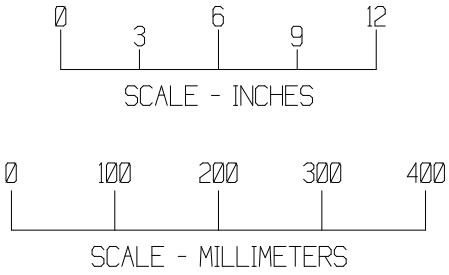

AQUA-AIR		MARINE AIR CONDITIONING SYSTEMS	
AC10H CHILLER UNIT w/SCROLL COMPRESSOR			
DRAWING NUMBER	AC10H	DRAWN BY	SB
		DATE	06-30-09
SCALE	FULL	APPROVED BY	DN
		REVISION DATE	
		REV	