

FEATURES

Modular Design

- White aluminum construction.
- Unique design allows either vertical or horizontal air discharge.
- Flexible design allows for alternate supply and return air locations.
- Pre-plumbed for either right or left connection.

Blower Assembly

- Permanent split capacitor motors for quiet, efficient operation.
- Fire retardant plastic blower housings.
- Framed filters are made of washable, fire retardant materials. Filters are attached to unit by stainless steel, "snapping" mount clips.
- Optional auxiliary heating elements available.

Fan Coil Assembly

- Enclosed insulated drain pan with threaded, dual drain connections for improved condensate removal.
- Fully insulated cabinetry.
- Internal 3-way valve assembly, with air bleeder.

Quality Assurance

- System matched components assure full BTU rating.
- All units meet or exceed applicable ABYC and U.S. Coast Guard regulations, CE Directives and general Air Conditioning and Refrigeration Industry (ARI) standards.

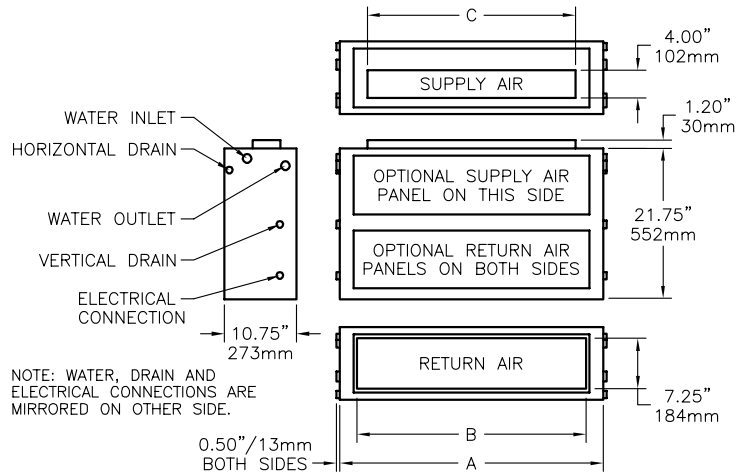

SPECIFICATIONS

Model	AH6K-SLL	AH9K-SLL	AH12K-SLL	AH18K-SLL	AH24K-SLL	AH30K-SLL	AH36K-SLL
Capacity (BTU/H)/(Kcal/H)	6,000/1,512	9,000/2,268	12,000/3,024	18,000/4,536	24,000/6,048	30,000/7,560	36,000/9,072
Voltage/Cycle @ 1 Phase	230/60 220/50	230/60 220/50	230/60 220/50	230/60 220/50	230/60 220/50	230/60 220/50	230/60 220/50
Amperage (FLA) Cool	0.8 0.8	0.8 0.8	0.8 0.8	0.8 0.8	0.8 0.8	1.6 1.6	1.6 1.6
Optional Electric Heaters (1)							
Element Size (kW)	1.0 1.0	1.0 1.0	1.0 1.0	3.0 3.0	3.0 3.0	3.0 3.0	3.0 3.0
Amperage (FLA) Heat	5.2 5.2	5.2 5.2	5.2 5.2	13.8 14.4	13.8 14.4	14.6 14.6	14.6 14.6
Rating (BTU/H)/(Kcal/H)	3,412/860	3,412/860	3,412/860	10,236/2579	10,236/2579	10,236/2579	10,236/2579
Max. Fuse/Min. Circuit Ampacity							
Without Electric Heat	5/2 5/2	5/2 5/2	5/2 5/2	5/2 5/2	5/2 5/2	5/3 5/3	5/3 5/3
With Electric Heat Option	10/6 10/6	10/6 10/6	10/6 10/6	20/15 20/15	20/15 20/15	20/16 20/16	20/16 20/16
GPM/(liters/min.)	1.5/5.7	2.25/8.5	3.0/11.4	4.5/17.0	6.0/22.7	6.0/22.7	6.0/22.7
CFM/(M ³ /Hr.) NOMINAL	200/340	300/510	400/680	600/1,019	750/1,274	1,000/1,699	1,200/2,039
Dimensions (in/mm)							
A (Unit Length)	20.00/508	24.00/610	32.00/813	38.00/965	44.00/1118	55.00/1397	62.00/1575
B (Return Air Grille Length)	15.00/381	19.00/483	27.00/686	33.00/838	39.00/991	50.00/1270	57.00/1448
C (Supply Air Opening Length)	12.00/305	16.00/406	24.00/610	30.00/762	36.00/914	47.00/1194	54.00/1372
Chilled Water Inlet/Outlet	0.50" FPT fitting and 0.625" HB			0.75" FPT fitting and HB		1.00" FPT fitting and HB	
Net Weight (lbs/kg) (2)	41/19	48/22	55/25	61/28	70/32	97/44	107/49
Gross Weight (lbs/kg) (2)	51/23	60/27	68/31	76/34	87/39	117/53	132/60

(1) Auxiliary heating elements are optional and must be pre-ordered with unit.

(2) Weights listed are for standard units. For weights of units with the electrical heater option, add heater elements weight to unit weight:

1.0kW = 3.0 lbs/1.4 kg; 1.5kW = 3.5 lbs/1.9 kg; and 3.0kW = 6.0 lbs/2.7 kg

Installation Guidelines for Slim Line Series Air Handlers

When choosing the proper model *Slim Line Air Handler(SLL)*, primary consideration should be given to calculated BTU loads and available power supply.

Slim Line Series air handlers are designed to be direct-discharge or ductable units. Airflow can be supplied to more than one area through the use of properly sized plenums, transitions and ductwork. The SLL configuration allows for installation in tight areas (shipside panels, narrow bulkhead spaces, short overheads, etc.) in either horizontal or vertical positions.

Securely fasten the SLL units to a solid level surface using the four (4) mounting holes provided in the base. The supply air outlet must be sealed properly either through cabinetry for direct-discharge, or into a plenum for a ductable discharge. All ductwork is to be routed as smooth and direct as possible. Any flexible ducting is to be secured every 48" (minimum) to prevent movement while the vessel is under operation. Trim off excess ducting before making final connections.

The return air inlet(s) must be properly sized and located to allow adequate airflow into the air handler. The SLL series air handlers have factory installed, removable filters to trap dust and other airborne particles. These filters must be accessible for maintenance. Return air inlets should not be located in such a way as to allow the supply air stream to blow directly into its opening. This will cause "short cycling" of the unit, resulting in poor or inadequate performance.

The supply air grille(s) must be sized and located to allow for proper air circulation within the cabin area(s). Grille locations close to the ceiling, or directed upward, provide the best air circulation. Undersized grilles and plenums, along with any crushed or kinked ductwork, will result in poor or inadequate performance.

Both condensation drain lines must be connected to the air handlers' two (2) drain pan spuds using reinforced flexible hose (5/8") and clamps. The drains may be

teed together, providing there is a minimum drop of 2" from the drain pan to the tee fitting. For installations on sailboats that heel over 15°, position air handlers so that the condensate pans drain port and starboard and use both drains teed together. Properly secure the drain lines to prevent movement or lifting during vessel operation. Check the drains upon completion by pouring two (2) quarts of water into the drain pan. **Note: Condensation drain lines may need to be insulated when located in overhead lockers to prevent sweating of the line, which could cause water damage.**

Never install your air conditioner air handler in bilge or engine room areas. Insure that the selected location is sealed from direct access to bilge and/or engine room vapors. Do not terminate condensate drain lines within four (4) feet of any outlet of engine or generator exhaust systems, nor in a compartment housing an engine or generator, nor in a bilge (vapors can travel up the drain line), unless the drain is connected properly to a sealed condensate or shower sump pump. Failure to comply may allow bilge or engine room vapors to mix with the air conditioners return air and contaminate living areas.

Water connections from the circulation circuit to the unit are to be reinforced flexible hose and double clamped, direction of clamps should be reversed. Attach the hose to the hose barb fittings on the water inlet and outlet of the unit. All hose, pipe and connections must be insulated properly to prevent condensation. Use approved closed cell tube insulation (1/2" minimum) on the hose, and foam tape on the fittings (5-6 wraps).

All wiring must be sized according to marine design standards. Only stranded, tinned copper wire is to be used. All electrical connections to the air handler are to be made inside the electrical junction boxes provided on the assembly. All units must be properly grounded. Ensure that power supply is turned off before opening electrical junction box.

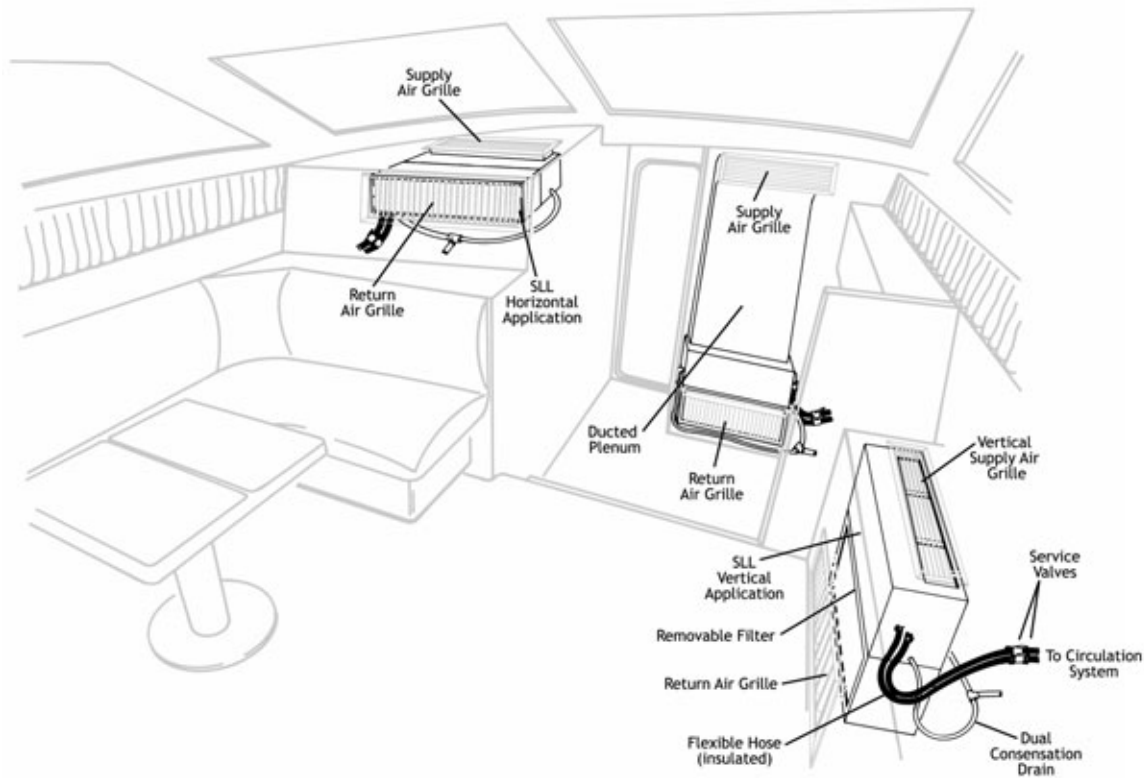

In the interest of product improvement, specifications and design as outlined herein are subject to change without prior notice.

Dometic Environmental Corporation

2000 N. Andrews Ave. Ext. • Pompano Beach, FL 33069-1497 USA
Phone: 954-973-2477 • Facsimile: 954-979-4414

P.O. Box 15299 • Richmond, VA 23227-0699 USA
Phone: 804-746-1313 • Facsimile: 804-746-7248

For Sales and Service Within Europe and the Middle East
Please Contact +44(0)870 3306101

Email: sales@marineair.com • Website: www.marineair.com

Sold and Serviced by: