

SXR12C Model Shown

Features

StowAway V Rotary

- 7,000 - 24,000 BTU/Hr
- 115V & 230V, 60 & 50 Hz models
- Reverse-cycle for heating & cooling
- Low-profile unit
- Rotatable blower for discharge in any direction
- Convenient pre-wired plug
- Quiet operation
- Lightweight
- Rotary compressor
- Low run current
- Low inrush current
- Available with R-417A refrigerant

SXR & SNR Models

- For use with SMX II/SMX Net control systems
- Pre-installed temperature sensor
- High & Low refrigerant pressure switches

SHR Models

- For use with SSA controls
- High refrigerant pressure switch
- Easily accessible terminal strip for wiring hookup

StowAway SXR, SNR and SHR Models

StowAway V rotary is a series of self-contained, direct-expansion, seawater-cooled, reverse-cycle air conditioners designed for marine use. This series of StowAways utilizes a rotary compressor, which offers quiet operation, light weight, and low starting and running power requirements.*

The StowAway V is available for 3 different control systems. SXR models come with a SMX II Power/Logic box, SNR units come with a SMX Net Power/Logic box and SHR models are designed for use with 3-knob switch assemblies.

The low-profile self-contained unit is designed to be installed under a settee or berth, in a locker or cabinet, or any other out-of-the-way location, with air ducted to a discharge-air grill which is normally placed high in the cabin. A return-air grill is situated low in the cabin.

The StowAway unit contains all air conditioning components, including the refrigerant compressor, condenser, evaporator, blower, receiver and accumulator, return-air filter, wiring and other associated components, mounted on a low-profile chassis. Hold-down clamps and condensate drain fittings are also included. The condensate drip pan is designed so that it encloses the entire drip line of the unit. The StowAway series has maximum efficiency of tubing size in the refrigerant circuit and, with accumulators and receivers, provides improved compressor performance and longevity in both the cooling and heating modes.

The highly efficient condenser coil contains a rifled/spiral heat exchanger with very little pressure drop. The evaporator coil contains rifled tubing and lanced fins to increase heat exchange. The squirrel-cage blower can be rotated for discharge in different directions. Optional high efficiency, internal motor blowers are available on SXRU models (all models except 24K).

The StowAway unit is designed for ease of installation and service. All wiring hookups and charging ports are conveniently located on top of the unit. The units are pre-charged and tested at the factory. The units are available in 7,000, 10,000, 12,000, 16,000 and 24,000 BTU/Hr capacities, in 115V and 230V, 60 and 50 Hz models. In addition to the basic StowAway rotary unit, the following components are required to complete the installation and are ordered separately: Seawater Cooling System, Air Distribution System, and Controls.

***Please note: SX24, SN24 and SH24 units use reciprocating, not rotary compressors.**

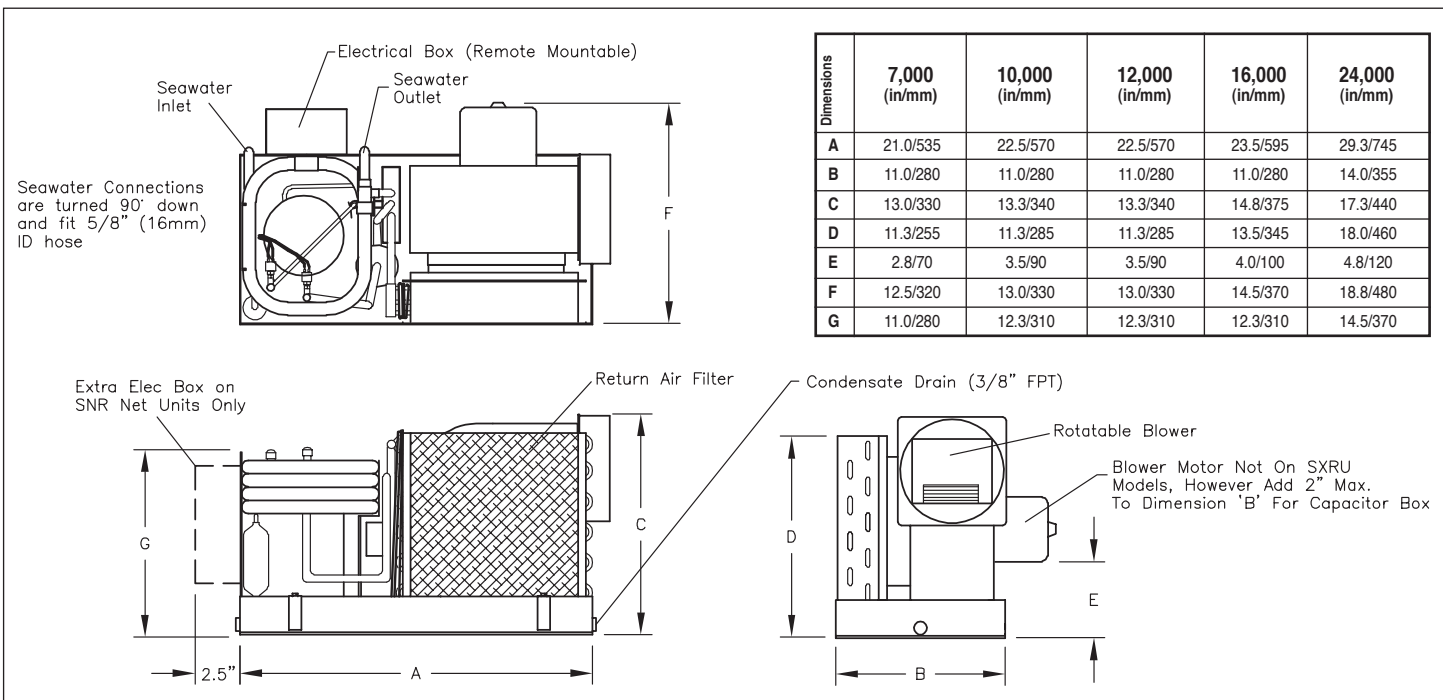

Dimensions	7,000 (in/mm)	10,000 (in/mm)	12,000 (in/mm)	16,000 (in/mm)	24,000 (in/mm)
A	21.0/535	22.5/570	22.5/570	23.5/595	29.3/745
B	11.0/280	11.0/280	11.0/280	11.0/280	14.0/355
C	13.0/330	13.3/340	13.3/340	14.8/375	17.3/440
D	11.3/285	11.3/285	11.3/285	13.5/345	18.0/460
E	2.8/70	3.5/90	3.5/90	4.0/100	4.8/120
F	12.5/320	13.0/330	13.0/330	14.5/370	18.8/480
G	11.0/280	12.3/310	12.3/310	12.3/310	14.5/370

TECHNICAL SPECIFICATIONS

Model	Capacity (Btu/hr)	Power* (Volts/Freq)	Cool Amps	Heat Amps	Start Amps**	Air Flow (cfm/cmh)	Weight (lb/kg)
SXR/SNR/SHR 7/1	7,000	115V/60Hz	6.4	8.0	24	200/340	58/26.3
SXR/SNR/SHR 7C1		230V/60Hz	2.8	3.7	11		
SXR/SNR/SHR 7CK1		220-240V/50Hz	3.2	3.8	11		
SXR/SNR/SHR 10	10,000	115V/60Hz	8.7	10.5	32	380/650	68/30.8
SXR/SNR/SHR 10C		230V/60Hz	4.3	5.5	17		
SXR/SNR/SHR 10CK		220-240V/50Hz	4.2	5.0	15		
SXR/SNR/SHR 12	12,000	115V/60Hz	10.5	11.5	35	380/650	70/31.8
SXR/SNR/SHR 12C		230V/60Hz	4.9	6.0	18		
SXR/SNR/SHR 12CK		220-240V/50Hz	4.8	6.0	18		
SXR/SNR/SHR 16	16,000	115V/60Hz	11.8	15.0	45	480/820	76/34.5
SXR/SNR/SHR 16C		230V/60Hz	5.9	7.5	23		
SXR/SNR/SHR 16CK		220-240V/50Hz	5.7	7.0	21		
SX/SN/SH 24C3	24,000	230V/60Hz	8.9	10.4	31	750/1280	140/63.5
SX/SN/SH 24CK3		220-240V/50Hz	10.2	11.5	35		

NOTE:
 *This 115V and 230V, 60 Hz equipment can be operated at 100V or 200V respectively, in a 50 Hz environment. In such a 50 Hz environment, rated capacity must be decreased by 17%. Full rated capacity may be obtained by specifying Cruisair "CK" equipment.

**Starting Amps vary with load and voltage, but are typically 2 to 3 times the full load running amps.

SPECIFYING GUIDE FOR ACCESSORIES

Unit Size (Btu/hr)	Return Air (sq. in/cm)	Discharge (sq. in/cm)	Duct (in/mm)	Seawater Flow (gpm/lpm)
7,000	80/516	45/290	5/125	2.3/9
10,000	100/645	60/387	6/150	3.3/13
12,000	130/839	70/452	6/150	4.0/15
16,000	160/1032	80/516	7/175	5.3/20
24,000	240/1548	140/903	9/225	8.0/30

INTERPRETING MODEL NUMBERS

